



P.O. Box 345
 Fowler, IN 47944
 (765) 884-0613
 Fax: (765) 884-0308
 Web: powellsystems.com

Date: _____

Quote Request for Powell Systems ES-100 Palletizer

General Information:

Contact Name:			
Company Name:			
Street Address:			
City:			
State:	Zip:		
Phone:		Fax:	
E-mail:			

Project Status: Order 0-90 days Order 90-180 days Information Only

CAD layout available on disk: * No Yes AutoCAD Version _____

*If not, please supply complete layout dimensions of the area(s) including locations of incoming product and outgoing finished goods, fork truck aisles, building supports, overhead clearances, drains, other equipment, obstructions, etc.

Palletizer Requirements:

Voltage:

- 115V (required)
 and
 230V/3/60 (recommended)
 or
 460V/3/60

Air:

- 60 PSI @ 2-3 CFM
 90 PSI @ 2-3 CFM (recommended)

Floor Space Available:

Approximate Square Feet _____
 (Not including in-feed conveyors)

Stacking Rate (cartons per minute)

- 4-6 6-8
 8-10 10-12
 Other _____

Product Information:

Product Type: RSC HSC POL FOL Returnable Other _____

Product Exit Height: (from existing conveyor) _____

Specific Contents: _____ Liquid Piece parts Granular

Carton Size(s):

Carton 1

Flaps	Open <input type="checkbox"/> Taped <input type="checkbox"/> Glued <input type="checkbox"/> Fan Fold <input type="checkbox"/>
Length	Inches
Width	Inches
Height	Inches
Weight (filled)	Pounds
Orientation	Labels Out <input type="checkbox"/> Yes <input type="checkbox"/> No

Carton 2

Flaps	Open <input type="checkbox"/> Taped <input type="checkbox"/> Glued <input type="checkbox"/> Fan Fold <input type="checkbox"/>
Length	Inches
Width	Inches
Height	Inches
Weight (filled)	Pounds
Orientation	Labels Out <input type="checkbox"/> Yes <input type="checkbox"/> No

Carton 3

Flaps	Open <input type="checkbox"/> Taped <input type="checkbox"/> Glued <input type="checkbox"/> Fan Fold <input type="checkbox"/>
Length	Inches
Width	Inches
Height	Inches
Weight (filled)	Pounds
Orientation	Labels Out <input type="checkbox"/> Yes <input type="checkbox"/> No

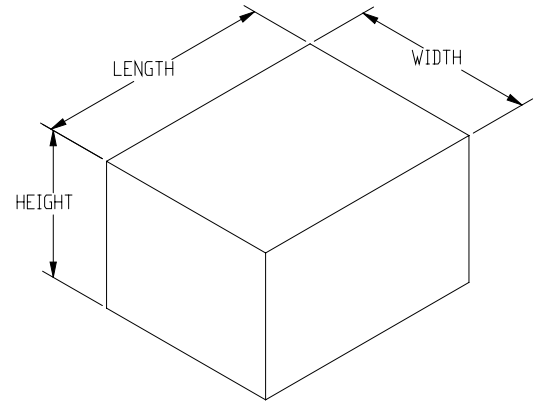

Returnable Size(s):

Buckhorn:

427-527E (with 427-528E lid) Lid Closing Required

427-516 (with 427-517 lid) Lid Closing Required

Filled Weight: _____

Orbis:

NSOA1408-7 (with lid) Lid Closing Required

NSO1215-5

Filled Weight: _____

Other (sample required):

Lid Closing Required

Product I.D.# _____

Length _____ Width _____ Height _____

Filled Weight: _____



Infeed Orientation
(Reference page 5 Palletizer Layout)

Width leading

Length leading

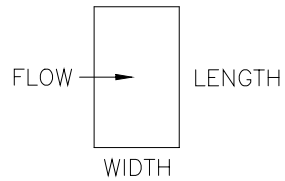
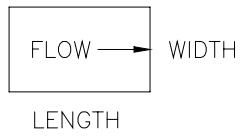

Patterns
(check all that apply)

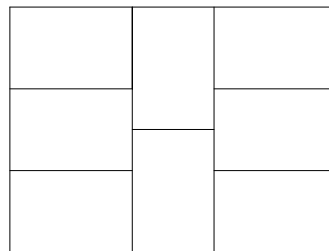
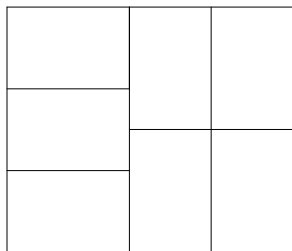
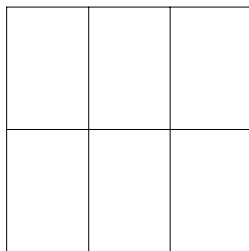
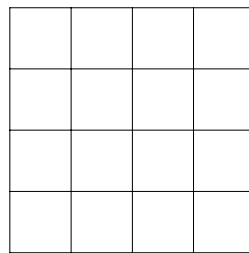
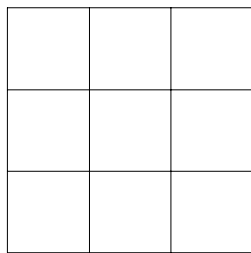
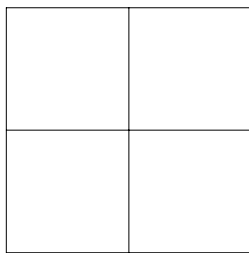

OTHER

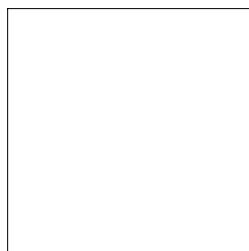

OTHER



Pallet Size(s)

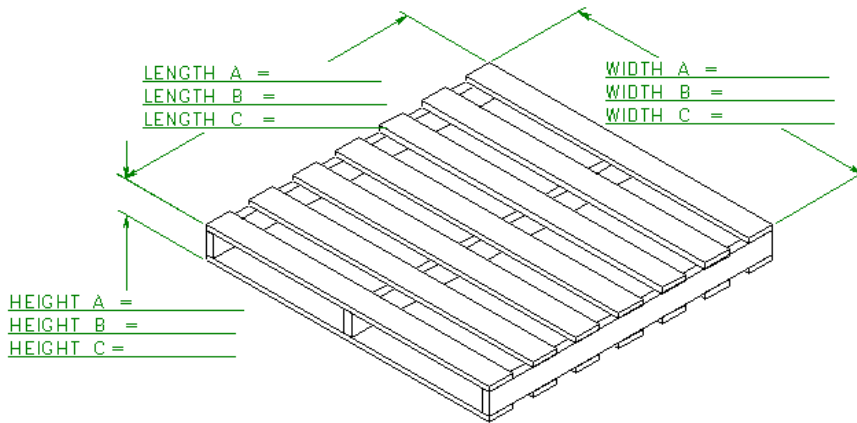

Pallet Type: Wood Plastic/Returnable

Pallet Style:
(check all that apply)

Grocery Ind. 4 Way Heavy Duty 2 Way Stringer Heavy Duty 4 Way Stringer

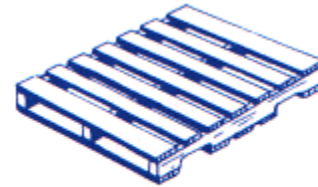
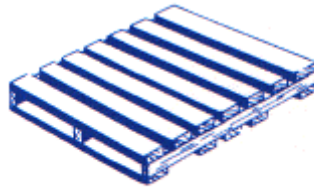
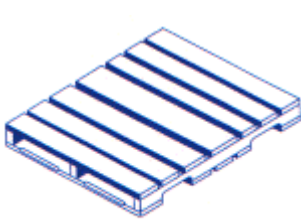

Perimeter Base Block

Single Faced

Standard Reversible

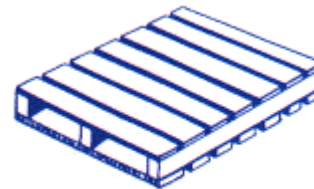
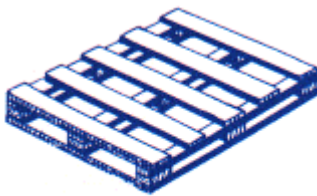

Double Wing

Single Wing

Other

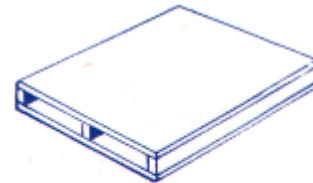
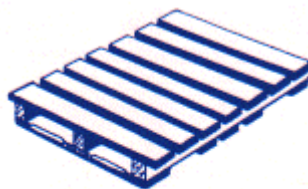
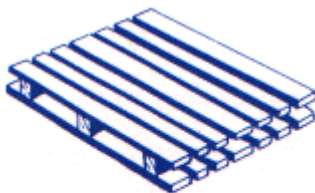

Loaded Pallet Configuration(s)

*Example:

3 Cartons 4 Rows 5 Layers

(example: 3 x 4 x 5)

Carton 1

___ Cartons ___ Rows ___ Layers

Carton 2

___ Cartons ___ Rows ___ Layers

Carton 3

___ Cartons ___ Rows ___ Layers

Carton 4

___ Cartons ___ Rows ___ Layers

Carton 5

___ Cartons ___ Rows ___ Layers

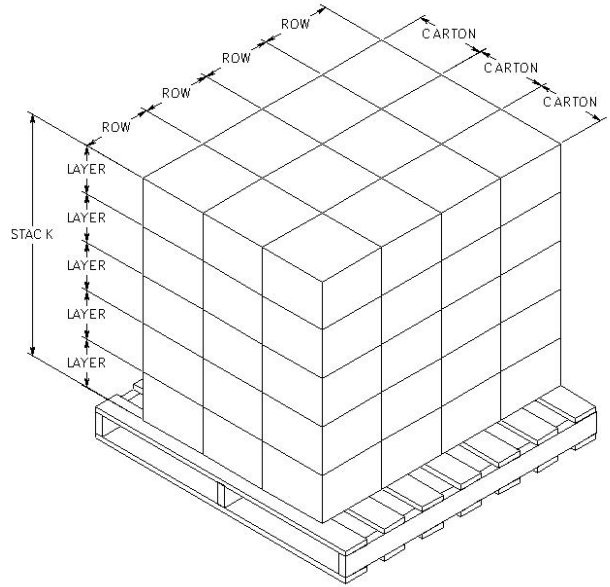

Palletizer Layout

